



BATTLECHIP

Team Members: Kristin Taylor (Team Lead), Erik Torkelson (Design Lead), Matt Weaver

Faculty Advisor: Dr. Nazanin Mansouri

University of Portland EE 483 Elect Engineering Capstone

9/28/2018

KRISTIN TAYLOR



MATT WEAVER



ERIK TORKELSON



PROJECT OVERVIEW - USER INTERFACE

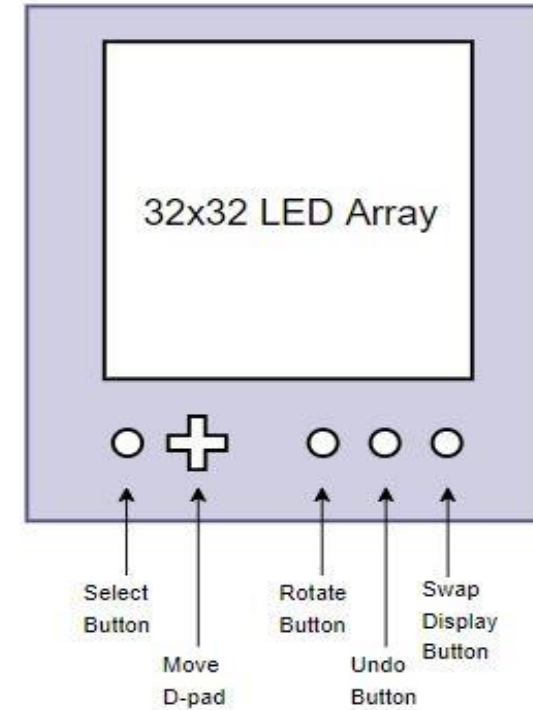
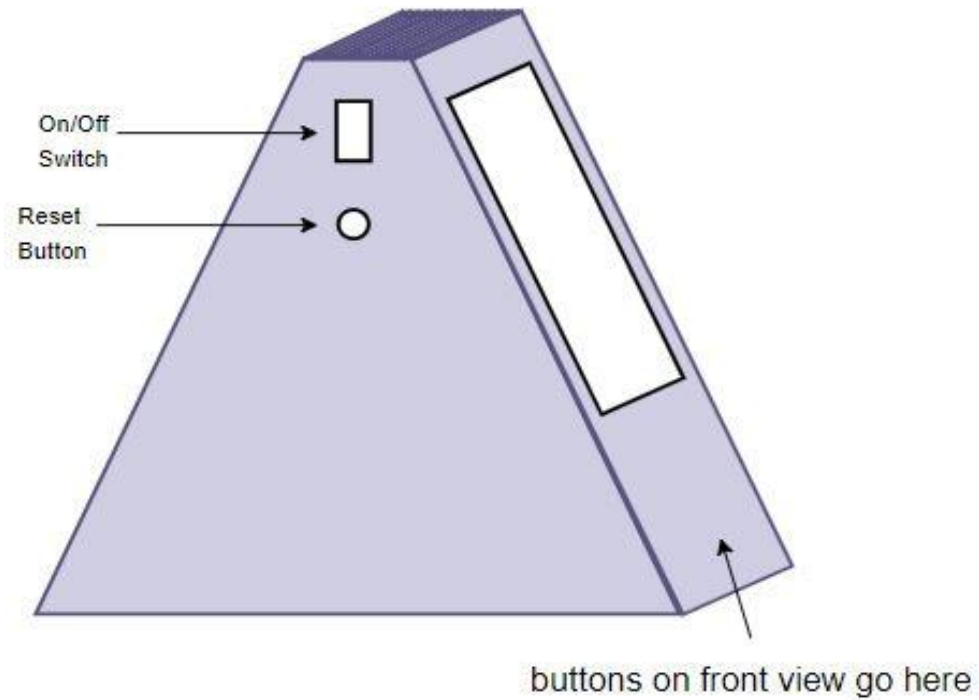

BLOCK DIAGRAM

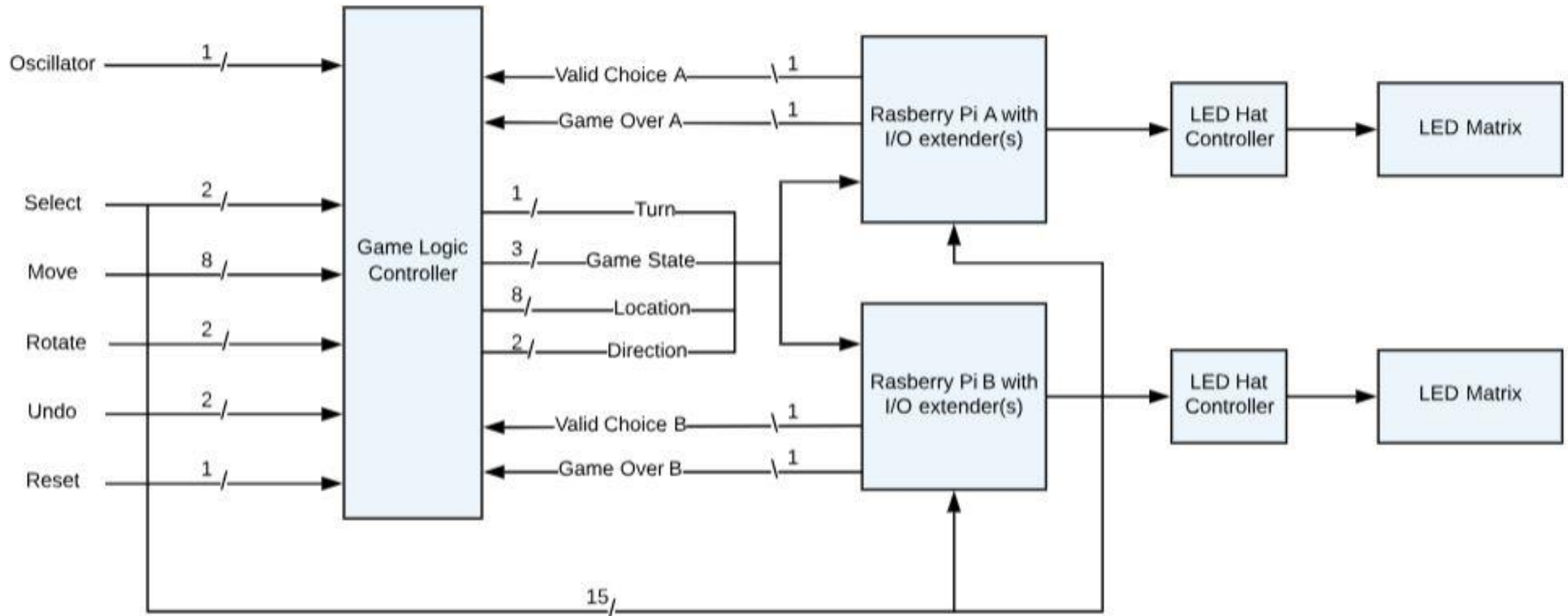

DEVELOPMENT PROCESS

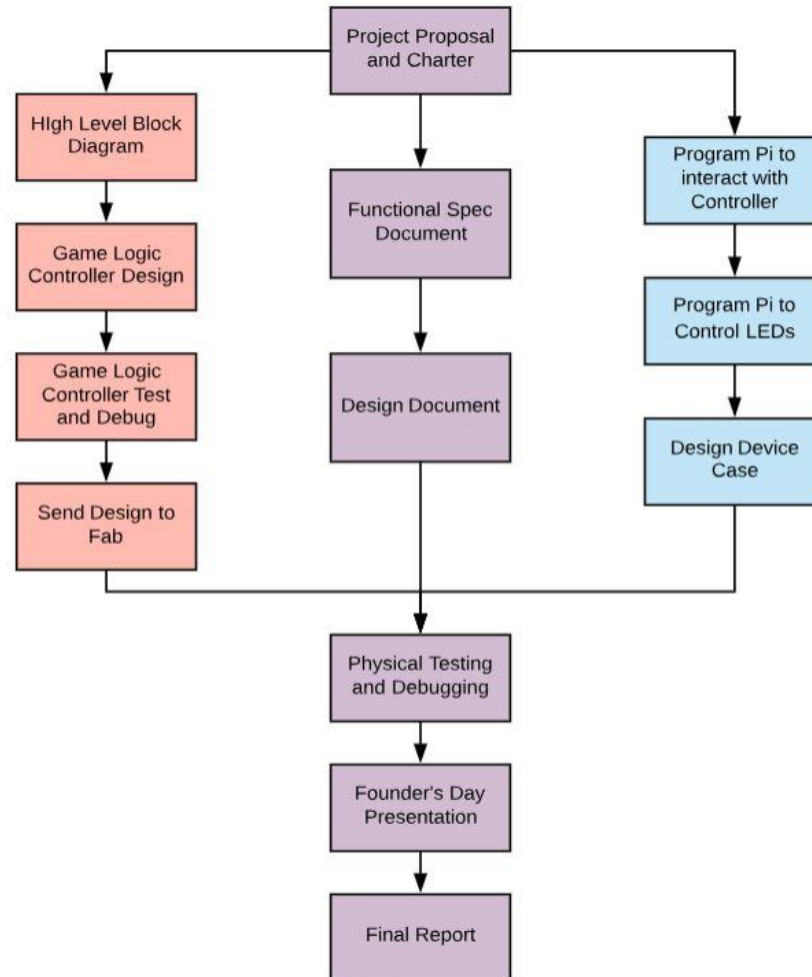

MILESTONES

Milestones	Completion Date
Functional Specification Document (ver 0.9)	September 22, 2018
Functional Specification Document (ver 0.95)	September 28, 2018
Functional Specification Document (ver 1.0)	October 12, 2018
Final Budget	October 26, 2018
Initial MOSIS EDIF file completed	October 26th
Design Document (ver 0.9)	November 2, 2018
Design Document (ver 0.95)	November 9, 2018
MOSIS EDF file, Verilog schematic completed	November 16, 2018
Design Document (ver 1.0)	November 30, 2018
Website Updated with Fall Documents	December 13, 2018
Hardware Test	March 1, 2018
Prototype Built	March 22, 2019
Founder's Day Presentations	April 9, 2019
Website Updated with Spring Documents	April 12, 2019

IMPORTANT DECISIONS

- User Inputs
- Display System
- Complexity of Game Logic Controller
- Interaction Between Pi and Chip
- Case Shape

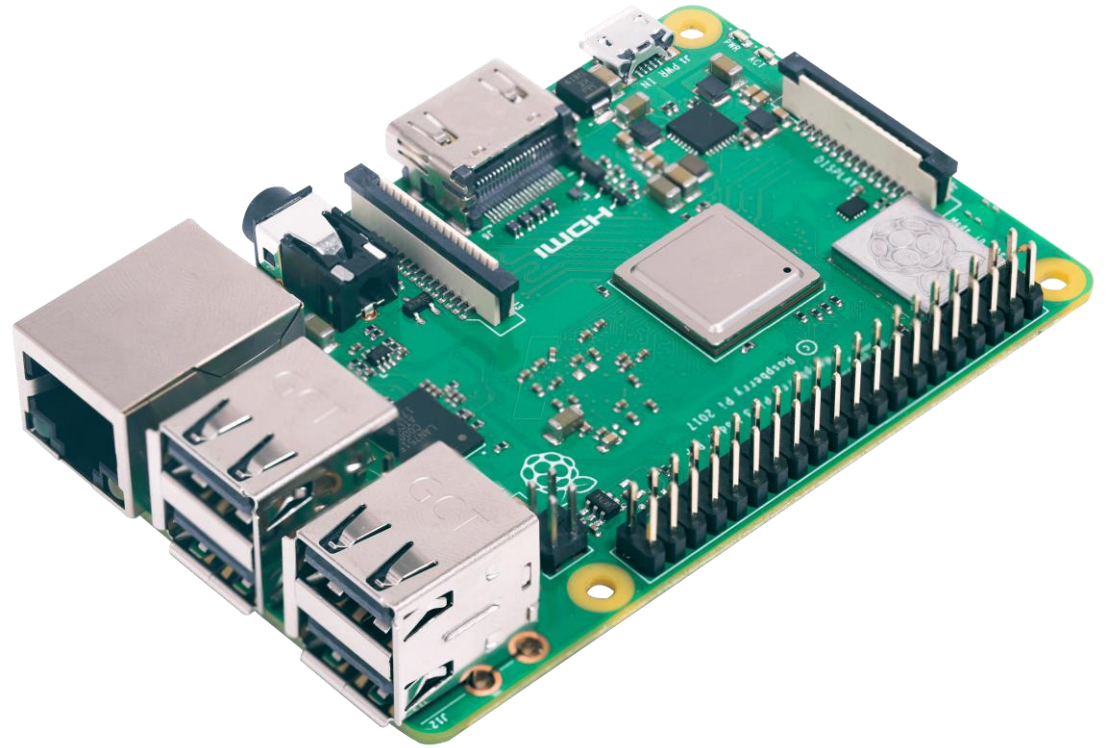

AREAS OF CONCERN

- Falling Behind Schedule
- Damaged Components
- Assembly Issues
- MOSIS Chip Problems and Delay
- Removal of Team Member



CONCLUSION





QUESTIONS?